

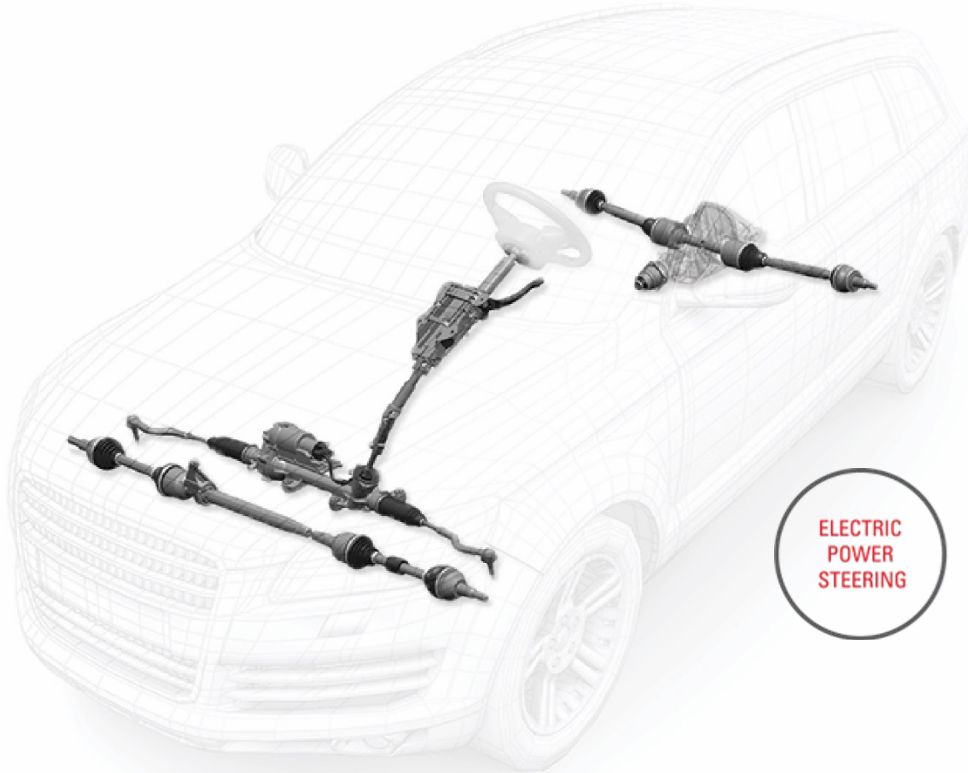

a leader in intuitive motion control



2021 Q1

Investor Communication

29 April 2021

ELECTRIC
POWER
STEERING

COLUMNS &
INTERMEDIATE
SHAFTS

DRIVELINE
SYSTEMS

HYDRAULIC
POWER
STEERING

ASSISTED
& AUTOMATED
DRIVING
ENABLERS

Presenters

BILL QUIGLEY

Senior Vice President
Chief Financial Officer



ROBIN MILAVEC

Senior Vice President
Chief Technology Officer
Chief Strategy Officer



Q1 Operating Environment & Status

Strong Customer Demand Driven Recovery Yet Below Pre-pandemic Level

Global Light Vehicle Production Unit Volume* Change %

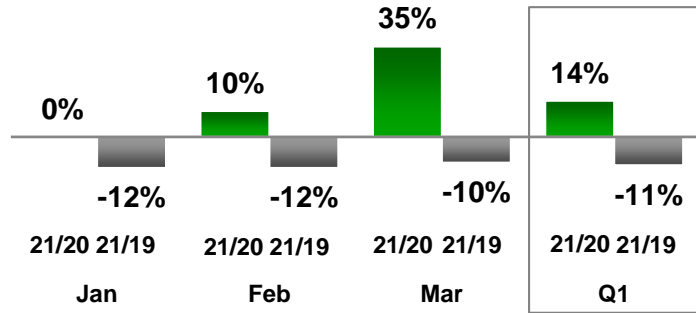

| (in millions) | Q1'21 | Q1'20 | % | Q1'19 | % |
|---------------|-------------|-------------|------------|-------------|-------------|
| Global | 20.3 | 17.8 | 14% | 22.9 | -11% |
| N. America | 3.6 | 3.8 | -4% | 4.2 | -15% |
| China | 5.8 | 3.3 | 77% | 6.0 | -4% |
| APAC | 10.9 | 8.2 | 33% | 11.7 | -7% |
| EMEASA** | 5.3 | 5.4 | 0% | 6.5 | -17% |

* April 2021 IHS Markit Ltd. forecast

** EMEASA includes Europe & S. America

Nexteer Status and Focus

- Continued growth-over-market in Q1
- Diligently manage through semiconductor / chip supply shortage to minimize customer impact
- Operational efficiency focus to mitigate headwinds from near-term production volatility
- People and Safety first priority

Full Year Production Expectations

Global Production - Forecast to Forecast Trend

IHS Markit Ltd. 2021 Global Light Vehicle Production Unit Forecast (in millions)

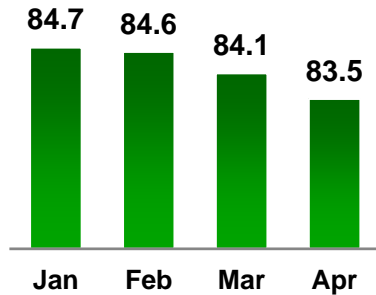

Markets Served

Light Vehicle Production Units

| (in millions) | Jan | April | % |
|---------------|------|-------|-------|
| NA | 16.3 | 15.7 | -3.7% |
| China | 24.8 | 24.6 | -0.8% |
| APAC | 44.5 | 44.3 | -0.4% |
| EMEASA* | 21.9 | 21.5 | -2.1% |

* EMEASA includes Europe & S. America

Unit Distribution

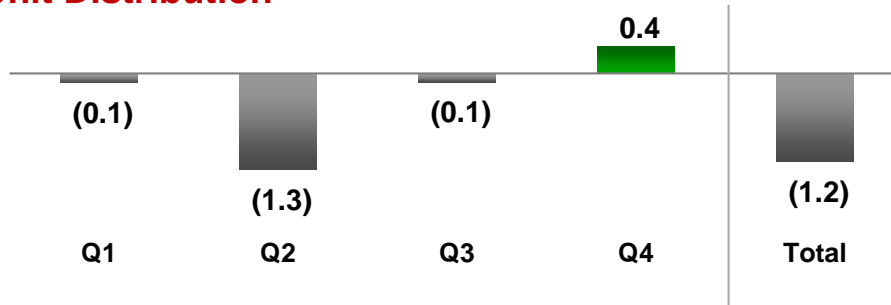

Near-Term

- IHS 2021 global OEM production forecast lowered by 1.2m units - 1.4% - Jan to April
- Semiconductor / chip supply constraint principal causal factor with Q2 current trough and recovery in Q3 / Q4
- OEM's adjusting production schedules quickly and frequently

Yet – Fundamentals Remain Constructive

- *Monetary / fiscal stimulus measures in place*
- *Accelerating C-19 treatment roll-out*
- *Evident economic recovery / growth*
- *Inventory replenishment and consumer demand*

Launched 9 Major Programs in Q1 2021

NORTH AMERICA
(2)



Jeep Grand Cherokee
REPS

Sheppard HD94-Class 8
Integral Gears

EMEASA
(3)



Renault Kangoo
Halfshafts



Renault Captur & Duster
Halfshafts



Dacia Express
Halfshafts



VW Jetta
Halfshafts



Renault Arkana
Halfshafts

APAC
(4)



GAC Aion Y
CEPS



Tata Limber EV
Halfshafts

Incumbent business | **New business**

 Electric Vehicle

Partnering with Sheppard on Commercial Vehicle ADAS

- Nexteer partnered with Sheppard to provide Magnetic Torque Overlay (MTO) and Advanced Driver Assist Steering technology on commercial trucks
- Sheppard has an 80+ year history of providing steering gears for commercial truck applications
- Nexteer has been in production for heavy duty passenger truck applications since 2015
- Start of production from January 2021

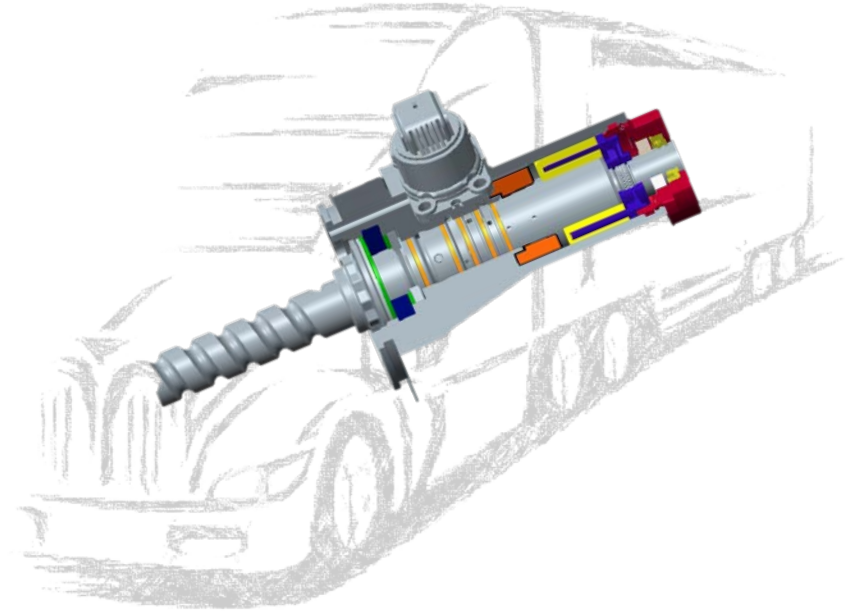

Business Wins - Q1 and 2021 Outlook

2021 Business Wins Outlook*

(\$ in millions)

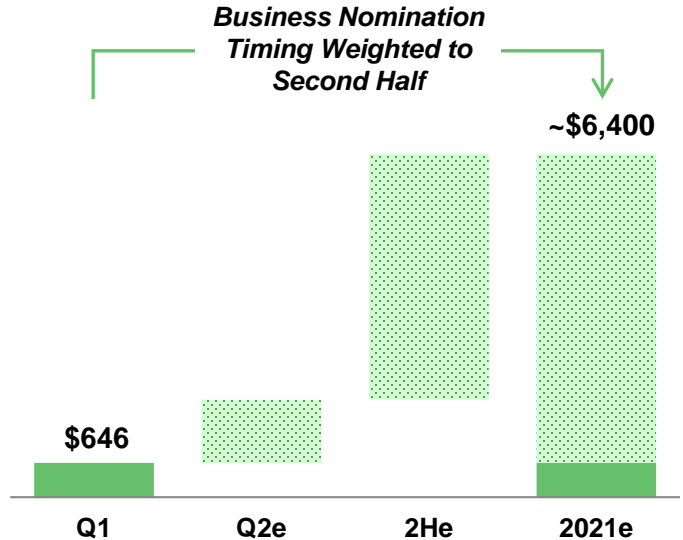

* Booked business information is compiled through our internal records, and such information has not been audited nor reviewed by our auditors.

Q1 Business Wins Composition

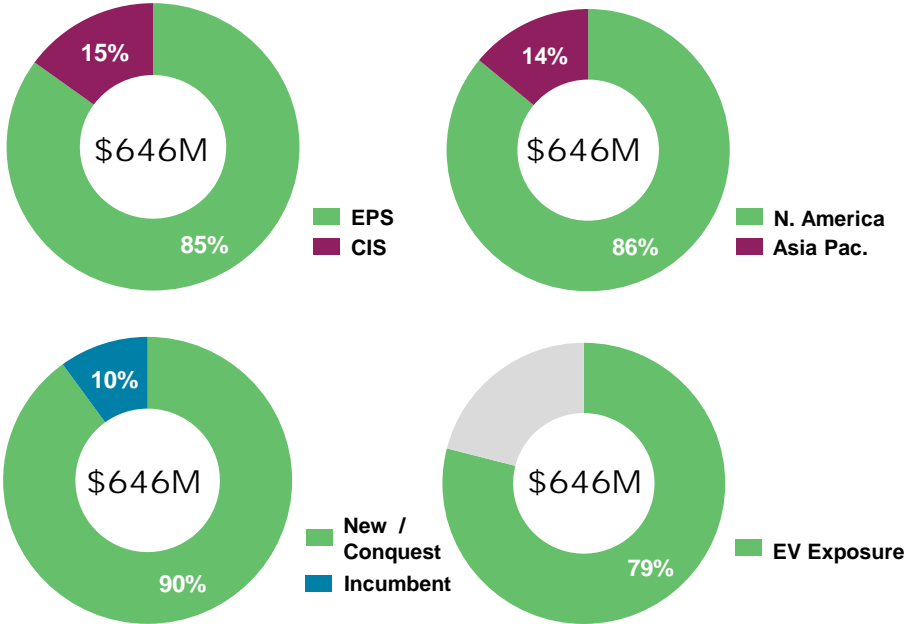

Advanced Technologies Roll-out on Electric Pick-up Trucks

Nexteer Well-Positioned in the Convergence of Electrification & Truck Segment

High-Output REPS



Ball Spline Axle



Column & I-Shaft Tech

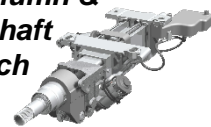

Chevy Electric Silverado

Nexteer's EPS, CIS & DL

High-Output REPS
Ball Spline Axle Halfshaft



GMC Electric Hummer

Nexteer's EPS, CIS & DL

High-Output REPS
Ball Spline Axle Halfshaft



Ford Electric F150

Nexteer's EPS & CIS

Organizational Enhancement Accelerates Software Innovation

Seamlessly integrating global software competence centers with a single strategic global software team

- **Accelerates** innovation-to-production timelines
- **Capitalizes** on exponential growth in software-enabled motion control solutions
- **Enhances** customer service, OEM technical consultation, software development and support
- **Maximizes** Nexteer's software value proposition
- **Enhances** global collaboration within Nexteer and its external partners



Automotive News

PACE pilot

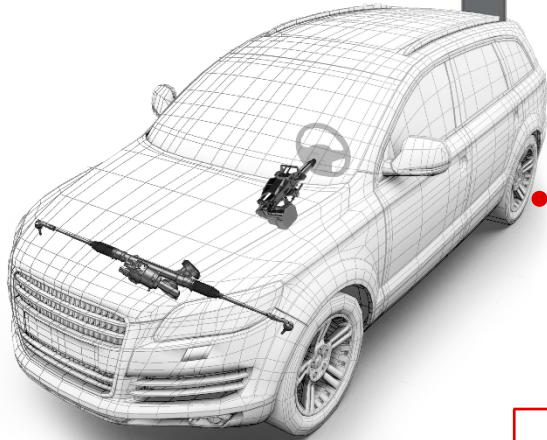

Two Nominations
by *Automotive News*
as 2021 PACE pilot Finalists

STEER-BY-WIRE with
STOWABLE STEERING COLUMN

